



北京猎鹰 鹰驰天下 猎遍九州

北京猎鹰集团
LIEYING BEIJING LIEYING GROUP



诚信 专业 创新 品质
Integrity, Professionalism, Innovation, Quality

专业生产高强度链条、搬运车、电动葫芦、手拉葫芦、手扳葫芦、吊装带、拉紧器
Specializing in the production of High-Strength Chains, Hand Pallet Trucks, Electric Hoist, Manual Hoist, Lever Hoist, Webbing Sling, Tie Down

安全提升 首选猎鹰
Safe Lifting Lieying Preferred

北京猎鹰起重机械设备集团有限责任公司

电话：0312-3021998

手机：15631258825

QQ：3471936547

邮箱：sales_LYJT@163.com

http://www.lieying-group.com

地址：河北保定市清苑东吕镇东吕工业园



安全提升 首选猎鹰 精工制造 安全可靠
专注起重、船舶30年 SINCE 1993

北京猎鹰起重机械设备集团有限责任公司
BEIJING LIEYING HOISTING MACHINERY EQUIPMENT GROUP CO., LTD.

● **公司愿景：管理优势 技术优势 领航未来**

Corporate vision; Management advantage
Technological superiority
Pilot for the future

● **经营理念：系统性提高一次性工作质量水平**

让市场和客户得到更安全 更可靠 更好的服务

Operation philosophy:

Systematic improvement of the quality of one-time work

Making the market and customers more secure,
reliable and better service

企业资质

Company Certificate



Company Profile

Beijing Lieying Group has four wholly owned subsidiaries, located in Qingyuan District, Baoding, Hebei province, the home of the famous Crane Watch, manufacturing and sales of large-scale enterprise culture base one. It has a history of more than 30 years. The manufacturing process of Beijing Lieying products is completed under the strict quality control system management. At present, it has passed the 131/9001:2015 International Quality System certification, and has passed the GS, qualified enterprises with quality standards, china's well-known brands and other multi-party certification, and has Hulu and other multi-product patents. At the same time we have PIOC insurance company every year 300 million product liability insurance. So that you can completely worry-free use of our products. The group's total "Automation, intelligence" supporting equipment and production of nearly 40), the product variety is close to species, we have, the central laboratory equipment configuration is the national experimental treasure recognized level), hand hoist workshop, lifting chain workshop, electric hoist workshop, disc motor workshop, forging workshop, rigging accessories workshop, lifting belt workshop, Heat Treatment Workshop has more than 10 modern workshops, throughout the country with marketing products outlets and warehouse total factory floor area of 30,000 square meters!

After years of development, Beijing Lieying Group's comprehensive strength in the forefront of the same industry in the country, we can provide research and development, production, sales, delivery, after-sales and other train services, it has formed five series of more than 1000 kinds of specifications and varieties, such as crane remote tool series, hardware rigging series, chain series, marine training ship fault, climbing frame electric hand-holding plate hoist series, etc. , its leading product series are: lifting tools are now: disc motor, lifting field new ring-knot electric hoist, micro-motor, micro-electric hoist and hand hoist. Ring chain electric hoist sound, standard: Sling series: high-strength synthetic fiber sling, lifting steel plate pliers, rigging accessories (hook-and-loop shackles) , steel wire rope, and combined rigging and other rigging products. G100, G120 lifting chain, hoist chain, stainless steel chain, mining chain, Hatch cover chain, and can be customized according to user needs non-standard chain.

Chain series: G30g80 C43C70 Marine Products Series: 12.5-124 mm 2 and 3 with the chain and accessories, 10-2000RC Marine: JIS rod-less, Houle, Spake, -14 HHP anchor, MK5 anchor, etc. , and according to customer needs to provide China CCS, the United States: BS, Britain LR, Japan N, France BV, Korea RR, Norway RN4 and DWT-L International Classification Society of Marine Products Original Certificate. Over the past 30 years, hunting group's products have been widely used in machinery, metallurgy, electric office, Railway, Water Conservancy, denunciation, aviation research, automobile, petrochemical and other industries, currently facing more than 30 provinces, cities and autonomous regions in China, more than 10 places, has provided more than 30 large enterprises, national key projects and tens of thousands of small and medium-sized enterprises safe and reliable, the special lifting tools and the use of product equipment, by the customer's praise and trust. At the same time far ou Ming, the Middle East, Southeast Asia, north and South and more than 50 homes and regions. Lieying for safety upgrade! Welcome to Lieying Group's broad platform to achieve win-win cooperation!

产品目录 Product Content

“北京猎鹰”可根据客户需求，研发、设计、生产制造，非标类产品/定制类产品。

"Beijing lieying" can be based on customer needs, R & D, design, manufacturing, non-standard products/custom products.

- 01-03 **高强度链条系列**
High Strength Chain Series
- 04-06 **搬运车堆高车系列**
Pallet truck Stacke Series
- 07-17 **电动葫芦系列**
Electric Hoist Series
- 18-24 **手拉葫芦/手扳葫芦系列**
Chain Block / Lever Hoist Series
- 25-26 **吊装带/拉紧器系列**
High Strength Webbing Sling EA & EB Series
- 27-34 **其他系列**
Ungroup Series

注：样本书中各类产品的尺寸公差详见相关的产品标准。

Note: the dimensional tolerances of all kinds of products in the sample book are detailed in the relevant product standards.

北京猎鹰公司产品由中国人寿财产保险股份有限公司承保

The products of Beijing Falcon Company are covered by China Life Property Insurance Co. Ltd.

“北京猎鹰”专业研发、生产制造起重索具类产品（电动环链葫芦提升机类/盘式电机类/起重链条类/起重索具配件类/起重合成纤维吊带类），五大类产品均具有行业独到的“工艺布置+优化水平”，产品采用“优质合金钢/优质高强度合成纤维”制成并经过热处理。超越性的技术优势，确保了产品的抗冲击能力、承载能力、韧性和延伸率，进一步提高了客户的使用安全性与使用寿命。产品满足“EN/ISO/DIN/BS/JIS/ASTM/GB”等国际/国家相关标准要求，破断强度质量等级达到G80级/G100级技术要求，可根据客户要求研发设计生产非标准类产品。北京猎鹰生产制造厂车间设备(部分):

"Beijing lieying" professional R & D, production and manufacture of lifting cable products (electric chain hoist class / disc motor class / lifting chain class / lifting rope accessories class / lifting reclosing fiber sling class), the five categories of products have the industry unique "optimization level of process layout", products are made of "high quality alloy steel / high quality high strength synthetic fiber" and heat treatment. The technical advantage of transcendence ensures the impact resistance, bearing capacity, toughness and elongation of the product, and further improves the safety and service life of the customer. The product meets the requirements of international / national standards such as "EN/ISO/DIN/BS/JIS/ASTM/GB", and the breaking strength quality grade reaches G80/ G100 level technical requirements, and can develop and produce non-standard products according to customer requirements. Beijing lieying manufacturing plant workshop equipment (part):



高强度链条系列

High Strength Chain Series

G70起重链条 G70 Lifting Chain



- ◆ 产品标准: EN 818—2 /ISO 3076 /DIN /BS /JIS /ASTM等
- ◆ 链条级别: G70
- ◆ 原材料: 优质合金钢
- ◆ 工艺控制: 严格执行标准要求/产品经过热处理
- ◆ 尺寸公差: 详见相关标准或客户订单要求
- ◆ 表面处理: 抛光、发黑、镀锌、喷塑等
- ◆ 注: 可根据客户需求研发生产制造非标产品

- ◆ Product Standard: EN 818-2/ISO 3076/DIN/BS/JIS/ASTM, etc.
- ◆ Chain level: G70
- ◆ Raw materials: high quality alloy steel
- ◆ Process control: Strict implementation of standard requirements / products after heat treatment
- ◆ Dimensional tolerance: See relevant standards or customer order requirements for details
- ◆ Surface treatment: polishing, blackening, galvanizing, spray molding, etc
- ◆ Note: Non-standard products can be developed and manufactured according to customer needs

规格 Size d × p (mm)	极限工作负荷 Extreme work load WLL/T (max)	破断力 Breaking Force BF/KN (min)	米重 Meters weight (kg/m)	节距 Pitch P (mm)	焊缝内宽 weld width a (mm)/(min)	焊缝外宽 weld width b (mm)/(max)
7 × 31.5	1.43	56	29.4	31.5	9.8	23.8
8.7 × 32.8	2.13	83.6	46.7	32.8	11.2	28.6
10 × 35	2.99	117.4	63.7	35	14	34
11.9 × 41.6	3.97	155.4	97	41.6	16.6	40.4
13 × 45.5	5.13	200.8	116.4	45.5	18.2	44.2
16 × 56	7.17	280.8	155	56	20	52
20 × 70	11.2	439.2		70	25	65



G80起重链条 G80 Lifting Chain



- ◆ 产品标准: EN 818—2 /ISO 3076 /DIN /BS /JIS /ASTM等
- ◆ 链条级别: G80
- ◆ 原材料: 优质合金钢
- ◆ 工艺控制: 严格执行标准要求/产品经过热处理
- ◆ 尺寸公差: 详见相关标准或客户订单要求
- ◆ 表面处理: 抛光、发黑、镀锌、喷塑等
- ◆ 注: 可根据客户需求研发生产制造非标产品

- ◆ Product Standard: EN 818-2/ISO 3076/DIN/BS/JIS/ASTM, etc.
- ◆ Chain level: G80
- ◆ Raw materials: high quality alloy steel
- ◆ Process control: Strict implementation of standard requirements / products after heat treatment
- ◆ Dimensional tolerance: See relevant standards or customer order requirements for details
- ◆ Surface treatment: polishing, blackening, galvanizing, spray molding, etc
- ◆ Note: Non-standard products can be developed and manufactured according to customer needs

规格 Size d × p (mm)	极限工作负荷 Extreme work load WLL/T (max)	破断力 Breaking Force BF/KN (min)	米重 Meters weight (kg/m)	节距 Pitch P (mm)	焊缝内宽 weld width a (mm)/(min)	焊缝外宽 weld width b (mm)/(max)
6 × 18	1.12	45.2	0.78	18	7.8	22.2
7 × 21	1.5	61.6	1.1	21	9.1	25.9
8 × 24	2.0	80.4	.35	24	10.4	29.6
9 × 27	2.5	102	1.8	27	11.7	33.3
10 × 30	3.2	126	2.13	30	13	37
11 × 33	3.8	152	2.7	33	14.3	40.7
12 × 36	4.2	181	3.1	36	15.6	44.4
13 × 39	5.0	212	3.7	39	16.9	48.1
14 × 42	6.3	246	4.1	42	18.2	51.8
16 × 48	8.0	322	5.26	48	20.8	59.2
18 × 54	10.0	407	6.8	54	23.4	66.6
20 × 60	12.5	503	9	60	26	74
22 × 66	15.0	608	10.9	66	28.6	81.4
23 × 69	16.0	665	12	69	29.9	85.1
25 × 75	20.0	785	14.1	75	32.5	92.5
26 × 78	21.2	849	15.2	78	33.8	96.2
28 × 84	25.0	985	17.6	84	36.4	104
32 × 96	31.5	1290	23	96	41.6	118

G100起重链条 G100 Lifting Chain



- ◆ 产品标准: EN 818—2 /ISO /DIN /BS /JIS /ASTM等
- ◆ 链条级别: G100
- ◆ 原材料: 优质合金钢
- ◆ 工艺控制: 严格执行标准要求/产品经过热处理
- ◆ 尺寸公差: 详见相关标准或客户订单要求
- ◆ 表面处理: 抛光、发黑、镀锌、喷塑等
- ◆ 注: 可根据客户需求研发生产制造非标产品

- ◆ Product Standard: EN 818-2/ISO/DIN/BS/JIS/ASTM, etc.
- ◆ Chain level: G100
- ◆ Raw materials: high quality alloy steel
- ◆ Process control: Strict implementation of standard requirements / products after heat treatment
- ◆ Dimensional tolerance: See relevant standards or customer order requirements for details
- ◆ Surface treatment: polishing, blackening, galvanizing, spray molding, etc
- ◆ Note: Non-standard products can be developed and manufactured according to customer needs

规格 Size d × p (mm)	极限工作负荷 Extreme work load WLL/T (max)	破断力 Breaking Force BF/KN (min)	米重 Meters weight (kg/m)	节距 Pitch P (mm)	焊缝内宽 weld width a (mm)/(min)	焊缝外宽 weld width b (mm)/(max)
6 × 18	1.4	56.5	0.9	18	7.8	22.2
7 × 21	1.9	77	1.2	21	9.1	25.9
8 × 24	2.5	101	1.6	24	10.4	29.6
10 × 30	4	157	2.5	30	13	37
13 × 39	6.7	212	4.2	39	16.9	48.1
16 × 48	10	402	6.2	48	20.8	59.2
18 × 54	12.5	509	8.1	54	23.4	66.6
20 × 60	16	628	10.0	60	26.0	74.0
22 × 66	19	760	11.9	66	28.6	81.4
26 × 78	26.5	1060	16.3	78	33.8	96.2

搬运车堆高车系列

Pallet truck Stacke Series

液压搬运车 Hand Hydraulic Pallet Truck

手动搬运车又名手动托盘搬运车, 其在使用时要将货叉插入托盘孔内, 由能力驱动液压系统来实现托盘货物的起升和下降, 并由人力拉动完成搬运作业。

手动托盘运输车是托盘运输工具中最简便、最有效、最常见的装卸、搬运工具。它广泛应用于物流、仓库、工厂、医院、学校、商场、机场、体育场馆、车站机场等等。配合我们公司的BFB系统手动托盘搬运车作业, 可以极大地提高工作效率, 减轻工人的劳动强度, 为企业赢得商场竞争的机会。

Hand Truck named Hand Pallet Truck again, the fork will insert the pallet hole when it's in use to realize the goods' rising and falling powered by hydraulic system controlled by manpower.

It is the most common tool for loading and carrying goods which is more convenient and effective. Because of the advantages, the hand pallet truck is widely used in logistics, warehouse, factory, hospital, school, shopping mall, airport, gymnasium, station etc.

The pallet truck can improve the work efficiency, reduce the labor's intensity and win the competition chance for the enterprise.



型号 Model	HPT-2-55	HPT-2-68	HPT-3-55	HPT-3-68	HPT-5-55	HPT-5-68
额定载重 Rated Load(kg)	2000	2000	3000	3000	5000	5000
货叉最高高度 Max Fork Height (mm)	200	200	200	200	200	200
货叉最低高度 Min.Fork Height (mm)	85	85	85	85	85	85
货叉长度 Fork Length (mm)	1150/1200	1150/1200	1150/1200	1150/1200	1150/1200	1150/1200
货叉外宽宽度 Fork Overall Width (mm)	550	685	550	685	550	685
整体高度 Height(mm)	1230	1230	1230	1230	1230	1230
单货叉宽 Single Fork Width(mm)	160	160	160	160	160	160
前轮尺寸(材质) Front-Wheel Size(Material)	80x70	80x70	80x70	80x70	85x66	85x66
后轮尺寸(材质) Rear-Wheel Size (Material)	180x50	180x50	180x50	180x50	180x52	180x52
净重 Net Weight(kg)	71	73	74	77	115	120
最小转弯半径 Radius(mm)	1250	1170	1350	1350	1350	1350

半电动液压搬运车 Semi-Electric Hydraulic Pallet Truck

半电动液压搬运车的优点：

1. 重量轻，容量大，良好的通行能力。重量轻，体积小巧，相当于一辆普通的手动液压搬运车的大小。
2. 专利设计：全新集成控制头设计，更容易更轻便操作。
3. 外部控制系统：专利设计的外部系统，不仅保护控制器到位，而且提供了方便的维护端口。
4. 运行：符合人体工程学设计的舵头有助于提高效率，内置的充电器，更方便充电。



Features of Semi Electric Hydraulic Pallet Truck:

1. light weight, great capacity, excellent passing ability.
light weight and compact size equivalent to hand pallet trucks.
2. Patented design:
New integrated control head design, easy & comfortable operation.
3. External control system:
Patent designed external control system not only protects controller in place but also provides easy access for maintenance.
4. Operation:
Ergonomically-designed tiller head helps increase efficiency; internal charger for easy charging.

额定载荷 Rate Capacity(kg)	2000	3000	5000
操作方式 Operate Model	Walkie		
轴距 Wheelbase	1170mm/1240mm		
最低高度 Min. Height	80mm		
最高起升高度 Max. Height	200mm		
货叉长度 Fork Length	1150mm/1200mm		
货叉外宽 Fork Width	550mm/685mm		
前轮单 Front wheel single	80x90		
前轮双 Front wheel double	Dia80x70		
转向轮 Steering wheel	180x50mm		
包装尺寸 Pack Size	1600X700X700mm		
行走速度 Speed	4/4.5km.h		
爬坡度 Climbing	3%-20%		
蓄电池电压/容量 Battery Capacity	24v/20Ah		
蓄电池类型 Battery	Lithium		
充电时间 Charging Time	2-5h		
工作时间 Working Time	4-6h		
转弯半径 Radius	1320/1390mm		
净重 Net Weight	140kg		

电动搬运车 Electric Pallet Truck

1. 大容量锂电池48v15A，能连续工作4小时，电池寿命长达3到5年。
2. 国家专业认证执照：CE 认证。
3. 高质量钢板，表面静电喷涂，既美观又耐磨。
4. 简单灵巧，转弯半径小，重量小。
5. 24V 28A，可拆卸铁锂电池。
6. 急停开关，壳式按钮和电磁制动，用来确保安全。

Advantages:

1. Large capacity Lithium battery:48V 15A can work continuously for 4 hours and battery life can be 3 to 5 years.
2. National professional certification license:CE certification.
3. High quality steel board and surface electrostatic spray, beauty and wear-resisting.
4. Simple and dexterous, with small turning radius and small weight.
5. 24V 28AH removable iron lithium battery.
6. Emergency stop switch, turtle button and Electromagnetic braking are used to ensure the safety.



型号 Product Code	EPT20-15ET2	EPT20-20ET
电池类型 Battery Type	Lead Acid Battery	Lead Acid Battery
电池容量 Battery Capacity	2 × 12V/65AH	4 × 12V/30AH
额定载荷 Load Capacity (kg)	1500kg	2000kg
最低叉高 Min Fork Height (mm)	80mm	80mm
最高叉高 Max Fork Height (mm)	200mm	200mm
叉长 Fork Length (mm)	1150mm	1150mm
叉外宽 Outer Width of Fork (mm)	560/685mm	560/685mm
叉内宽 Internal Width of Fork (mm)	260/385mm	260/385mm
整体尺寸 Overall Dimension (mm)	1638 × 685 × 1170mm	1638 × 685 × 1170mm
净重 Dead Weight (kg)	180kg	220kg
充电器型号 Battery Charger	AC220V/50HZ/10A	AC220V/50HZ/10A

电动葫芦系列 Electric Hoist Series

电动环链葫芦 KBK Electric Chain Hoist

高效、质轻电机，无石棉刹车系统，低能耗。冲压钢构壳体，轻巧而坚固。高强度安全吊钩，承受意外超负荷冲出不会发生断裂，只是逐渐变形。轻功、美观而耐用的塑制链袋。

极限开关:吊上吊下都有极限开关装置，使电机自动停止，反防止链条炒出，确保安全。逆相保护装置:特殊电线装置，当电源接线错误时，控制电路无法工作。



电动环链葫芦 KBK Electric Chain Hoist

High efficiency, light weight motor, no asbestos brake system, low energy consumption. Stamping Steel shell, lightweight and strong. High strength safety hook, bear unexpected overload rush out will not break, just gradually deformation. Light weight, beautiful and durable plastic chain bag.

Limit Switch: there is a limit switch device hanging up and down, so that the motor automatically stop, anti-prevent chain fried, to ensure safety. Reverse phase protection device: special wire device, when the power connection is wrong, the control circuit can not work.



单速 Single speed

型号 Model	额定载荷 Capacity (Ton)	起升速度 Lifting speed (m/min)	电机功率 Motor power (Kw)	运行速度 Running speed (m/min)	电机转速 Rotation speed (m/min)	电机绝缘等级 Insulation grade	工作电压 Power supply	控制电压 Control voltage	链条回数 No. of load chain	链条规格 Spec. of load chain	梁宽 I Beam (mm)
0.25-01S	0.25	7.2	0.8	11&21	1440	F	3P/220V-690V	24V/36V/48V	1	φ 6.3	75-125
0.5-01S	0.5	7.2	0.8	11&21	1440	F	3P/220V-690V	24V/36V/48V	1	φ 6.3	75-125
0.1-01S	1	6.6	1.5	11&21	1440	F	3P/220V-690V	24V/36V/48V	1	φ 7.1	75-125
1.5-01S	1.5	8.8	3.0	11&21	1440	F	3P/220V-690V	24V/36V/48V	1	φ 10.0	75-125
02-01S	2	6.6	3.0	11&21	1440	F	3P/220V-690V	24V/36V/48V	1	φ 10.0	75-125
02-02S	2	3.3	1.5	11&21	1440	F	3P/220V-690V	24V/36V/48V	2	φ 7.1	75-125
2.5-01S	2.5	5.4	3.0	11&21	1440	F	3P/220V-690V	24V/36V/48V	1	φ 11.2	82-153
03-01S	3	5.4	3.0	11&21	1440	F	3P/220V-690V	24V/36V/48V	1	φ 11.2	82-153
03-02S	3	4.4	3.0	11&21	1440	F	3P/220V-690V	24V/36V/48V	2	φ 10.0	82-153
05-02S	5	2.7	3.0	11&21	1440	F	3P/220V-690V	24V/36V/48V	2	φ 11.2	100-178
7.5-02S	7.5	1.8	3.0	11&21	1440	F	3P/220V-690V	24V/36V/48V	3	φ 11.2	112-178
10-04S	10	2.7	3.0×2	11&21	1440	F	3P/220V-690V	24V/36V/48V	4	φ 11.2	112-178
15-06S	15	1.8	3.0×2	11&21	1440	F	3P/220V-690V	24V/36V/48V	6	φ 11.2	150-220
20-08S	20	1.4	3.0×2	11&21	1440	F	3P/220V-690V	24V/36V/48V	8	φ 11.2	150-220
25-10S	25	1.1	3.0×2	11&21	1440	F	3P/220V-690V	24V/36V/48V	10	φ 11.2	150-220

单速 Single speed

型号 Model	额定载荷 Capacity (Ton)	起升速度 Lifting speed (m/min)	电机功率 Motor power (Kw)	运行速度 Running speed (m/min)	电机转速 Rotation speed (m/min)	电机绝缘等级 Insulation grade	工作电压 Power supply	控制电压 Control voltage	链条回数 No. of load chain	链条规格 Spec. of load chain
0.5-01S	0.5	7.2	0.8	11&21	1440	F	3P/220V-690V	24V/36V/48V	1	φ 6.3
0.1-01S	1	6.6	1.5	11&21	1440	F	3P/220V-690V	24V/36V/48V	1	φ 7.1
1.5-01S	1.5	8.8	3.0	11&21	1440	F	3P/220V-690V	24V/36V/48V	1	φ 10.0
02-01S	2	6.6	3.0	11&21	1440	F	3P/220V-690V	24V/36V/48V	1	φ 10.0
02-02S	2	3.3	1.5	11&21	1440	F	3P/220V-690V	24V/36V/48V	2	φ 7.1
2.5-01S	2.5	5.4	3.0	11&21	1440	F	3P/220V-690V	24V/36V/48V	1	φ 11.2
03-01S	3	5.4	3.0	11&21	1440	F	3P/220V-690V	24V/36V/48V	1	φ 11.2
03-02S	3	4.4	3.0	11&21	1440	F	3P/220V-690V	24V/36V/48V	2	φ 10.0
05-02S	5	2.7	3.0	11&21	1440	F	3P/220V-690V	24V/36V/48V	2	φ 11.2
7.5-02S	7.5	1.8	3.0	11&21	1440	F	3P/220V-690V	24V/36V/48V	3	φ 11.2
10-04S	10	2.7	3.0×2	11&21	1440	F	3P/220V-690V	24V/36V/48V	4	φ 11.2

双速 Double speed

型号 Model	额定载荷 Capacity (Ton)	起升速度 Lifting speed (m/min)	电机功率 Motor power (Kw)	运行速度 Running speed (m/min)	起升电机转速 Rotation speed (m/min)	电机绝缘等级 Insulation grade	工作电压 Power supply	控制电压 Control voltage	链条回数 No. of load chain	链条规格 Spec. of load chain
0.25-01D	0.25	7.2/2.4	0.8/0.27	20/5	2880/960	F	3P/220V-690V	24V/36V/48V	1	φ 6.3
0.5-01D	0.5	7.2/2.4	0.8/0.27	20/5	2880/960	F	3P/220V-690V	24V/36V/48V	1	φ 6.3
0.1-01D	1	6.9/2.3	1.8/0.6	20/5	2880/960	F	3P/220V-690V	24V/36V/48V	1	φ 7.1
1.5-01D	1.5	9.0/3.0	3.0/1.0	20/5	2880/960	F	3P/220V-690V	24V/36V/48V	1	φ 10.0
02-01D	2	6.9/2.3	3.0/1.0	20/5	2880/960	F	3P/220V-690V	24V/36V/48V	1	φ 10.0
02-02D	2	3.3/1.1	1.8/0.6	20/5	2880/960	F	3P/220V-690V	24V/36V/48V	2	φ 7.1
2.5-01D	2.5	5.4/1.8	3.0/1.0	20/5	2880/960	F	3P/220V-690V	24V/36V/48V	1	φ 11.2
03-01D	3	5.4/1.8	3.0/1.0	20/5	2880/960	F	3P/220V-690V	24V/36V/48V	1	φ 11.2
03-02D	3	4.5/1.5	3.0/1.0	20/5	2880/960	F	3P/220V-690V	24V/36V/48V	2	φ 10.0
05-02D	5	2.7/0.9	3.0/1.0	20/5	2880/960	F	3P/220V-690V	24V/36V/48V	2	φ 11.2
7.5-02D	7.5	1.8/0.6	3.0/1.0	20/5	2880/960	F	3P/220V-690V	24V/36V/48V	3	φ 11.2
10-04D	10	2.7/0.9	3.0×2/1.0×2	20/5	2880/960	F	3P/220V-690V	24V/36V/48V	4	φ 11.2
15-06D	15	1.8/0.6	3.0×2/1.0×2	20/5	2880/960	F	3P/220V-690V	24V/36V/48V	6	φ 11.2
20-08D	20	1.5/0.5	3.0×2/1.0×2	20/5	2880/960	F	3P/220V-690V	24V/36V/48V	8	φ 11.2
25-10D	25	1.2/0.4	3.0×2/1.0×2	20/5	2880/960.2	F	3P/220V-690V	24V/36V/48V	10	φ 11.2

双速 Double speed

型号 Model	额定载荷 Capacity (Ton)	起升速度 Lifting speed (m/min)	电机功率 Motor power (Kw)	运行速度 Running speed (m/min)	起升电机转速 Rotation speed (m/min)	电机绝缘等级 Insulation grade	工作电压 Power supply	控制电压 Control voltage	链条回数 No. of load chain	链条规格 Spec. of load chain
0.5-01LD	0.5	7.2/2.4	0.8/0.27	20/5	2880/960	F	3P/220V-690V	24V/36V/48V	1	φ 6.3
01-01LD	1	6.9/2.3	1.8/0.6	20/5	2880/960	F	3P/220V-690V	24V/36V/48V	1	φ 7.1
1.5-01LD	1.5	9.0/3.0	3.0/1.0	20/5	2880/960	F	3P/220V-690V	24V/36V/48V	1	φ 10.0
02-01LD	2	6.9/2.3	3.0/1.0	20/5	2880/960	F	3P/220V-690V	24V/36V/48V	1	φ 10.0
02-02LD	2	3.3/1.1	1.8/0.6	20/5	2880/960	F	3P/220V-690V	24V/36V/48V	2	φ 7.1
2.5-01LD	2.5	5.4/1.8	3.0/1.0	20/5	2880/960	F	3P/220V-690V	24V/36V/48V	1	φ 11.2
03-01LD	3	5.4/1.8	3.0/1.0	20/5	2880/960	F	3P/220V-690V	24V/36V/48V	1	φ 11.2
03-02LD	3	4.5/1.5	3.0/1.0	20/5	2880/960	F	3P/220V-690V	24V/36V/48V	2	φ 10.0
05-02LD	5	2.7/0.9	3.0/1.0	20/5	2880/960	F	3P/220V-690V	24V/36V/48V	2	φ 11.2
7.5-03LD	7.5	1.8/0.6	3.0/1.0	20/5	2880/960	F	3P/220V-690V	24V/36V/48V	3	φ 11.2
10-04LD	10	2.7/0.9	3.0×2/1.0×2	20/5	2880/960	F	3P/220V-690V	24V/36V/48V	4	φ 11.2

DHS电动葫芦 DHS Electric Hoist



主要特点:

- 1、紧急停止开关;
- 2、强化制动开关;
- 3、保护等级高达IP54;
- 4、热保护装置;
- 5、上下限位装置。

Main Features:

1. With urgent stop switch;
2. With reinforced breaking switch with position;
3. Protection class up to IP54;
4. With thermal protection device;
5. With up and down limit device.

DHS型环链电动葫芦是一种新型小型起重设备;是起吊、运送、装卸货物、工件的理想设备。它广泛用于各行各业的加工车间、仓库、码头、建筑业、各类商店及各种商店及各种现代化的生产流水线, 装配线。在空间较小的工作场所使用更是灵活迅捷, 安全方便。DHS型环链电动葫芦具有当代世界先进水平。在国际市场上享有盛誉。

DHS type ring chain electric hoist is a new type of small lifting equipment; it is an ideal equipment for lifting, transporting, loading and unloading goods and workpieces. It is widely used in all kinds of processing workshops, warehouses, docks, construction industry, various stores and various modern production lines, assembly lines. Use in smaller workplaces is more flexible and quick, safe and convenient. DHS type ring chain electric hoist has the advanced level in the contemporary world. prestigious in the international market.

型号 Model	DHS1	DHS2	DHS3	DHS5	DHS10
额定荷载 Rated Load (T)	1	2	3	5	10
电机型号 Type of motor	YHPE500-4	YHPE500-4	YHPE500-4	YHPE500-4	YHPE500-4
电源电压 Power Voltage (V, Hz)	380V 50Hz				
接电持续率 Electricity Duration (JC)	40%	40%	40%	40%	40%
电机转速 Motor speed (r/min)	1380	1380	1380	1380	1380
提升速度 Lifting speed (m/min)	2.2	1.8	1.1	0.9	0.45
起升高度 Lifting height (m)	3-12				
试验荷载 Test Load (T)	1.25	2.5	3.75	6.25	12.5
电机功率 Motor Power (W)	500	750	750	750	750
链条行数 NO.of chain x Dia(mm)	1×6	1×10	2×10	2×10	4×10
整机重量 Machine weight (kg)	3m 36	45	42	57	95
装箱尺寸 Package Size(cm)	6m 40	52	50	70	120
	50×32×28	50×32×30	50×32×30	50×32×32	60×32×32

DHP型电动葫芦 DHP Type Electric Hoist

DHP型电动葫芦因主要用于大型油罐, 建筑爬架, 所以又称群吊电动葫芦。DHP型群吊电动葫芦是北京猎鹰起重设备有限公司在生产HSZ型手拉葫芦的基础上改进设计而成的, 采用盘式制动电机作动力, 行星减速器减速。为大型油罐焊接安装必备起重设备, DHP型群吊电动葫芦具有结构紧凑、体积小、重量轻、效率高、使用方便、制动可靠、维护简单等特点。

DHP型群吊电动葫芦适用于低速小行程的物料装卸、设备安装、矿山及工程建筑等方面, 具有起吊速度慢, 机体重量轻, 机件硬度高, 磨损小的特点。它广泛用于各行各业的加工车间、仓库、码头、及各种现代化的生产流水线, 装配线。在空间较小的工作场所使用更是灵活迅捷, 安全方便, 还适合于建筑工程领域的爬架, 模具的提升, 大型油罐的群吊, 具有当代世界先进水平。

DHP electric hoist is mainly used for large oil tank, building climbing frame, so it is also called group hoist electric hoist. DHP group hoist electric hoist is designed by Beijing Falcon Lifting Equipment Co., Ltd. on the basis of the production of HSZ hand-drawn hoist, using disk brake motor as power, planetary reducer deceleration. necessary lifting equipment for large oil tank welding installation, dhp type group crane electric hoist has the characteristics of compact structure, small size, light weight, high efficiency, convenient use, reliable braking and simple maintenance.

DHP type group hoist electric hoist is suitable for low speed and small stroke material handling, equipment installation, mine and engineering construction, etc. It has the characteristics of slow lifting speed, light body weight, high hardness of machine parts and small wear. It is widely used in various industries processing workshop, warehouse, wharf, and various modern production lines, assembly lines. The use in the smaller space workplace is more flexible and quick, safe and convenient, but also suitable for the construction engineering field of climbing frame, mold lifting, large oil tank group crane, with the advanced level of the contemporary world.



型号 Model	5T	7.5T	10T	20T	30T
额定荷载 Rated load (ton)	5	7.5	10	20	30
试验荷载 Test load (t)	6.25	9.5	12.5	25	37.5
电机功率 Motor power (kw)	0.5	0.5	0.5	0.5	0.75
电源电压 Supply voltage	380V 50Hz				
提升速度 Lifting speed (m/min)	0.18	0.12	0.09	0.09	0.06
两钩间最小距离 Minimum distance between two hooks (mm)	600	660	730	1040	1480
起重链条行数 Falls of chain	2	3	4	8	12
标准起升高度 Standard lifting height (m)	3				
起重链条圆钢直径 Dia of lifting chainr (mm)	10	10	10	10	10
净重 N.W (kg)	58	70	95	195	285
装箱毛量 G.W(kg)	69	80	108	225	325
装箱尺寸长×宽×高 Packing size L×W×H (cm)	46×42×42	46×42×42	54×46×42	74×70×45	95×77×45
每增加一米增加重量 Added weight per 1m lift (kg)	4.4	6.6	8.8	17.6	25.2

CD1、MD1型钢丝绳电动葫芦 CD1、MD1 Type wire rope Electric Hoist

CD1、MD1型电动葫芦具有结构紧凑、自重轻、体积小、操作方便等特点，是一种轻小型起重设备。它可以装在葫芦单梁、桥式起重机、门式起重机、悬臂起重机等多种起重机上。稍加改动就可以作卷扬机使用。因此，它是工厂、矿山、港口、仓库、货场、商店等常用的起重设备之一，是提高劳动效率、改善劳动条件的必备机械。CD1型电动葫芦的起升速度为常速，可以满足一般场合的使用要求。

CD1, MD1 electric hoist with compact structure, light weight, small size, easy to operate and so on, is a light and small lifting equipment. It can be installed in gourd single beam, bridge crane, portal crane, cantilever crane and many other cranes. A few changes can be used for a hoist. Therefore, it is one of the commonly used lifting equipment in factories, mines, ports, warehouses, freight yards, shops and so on, and it is a necessary machinery to improve labor efficiency and improve labor conditions. The lifting speed of CD1 electric hoist is constant speed, which can meet the requirements of general occasions.

CD1



MD1

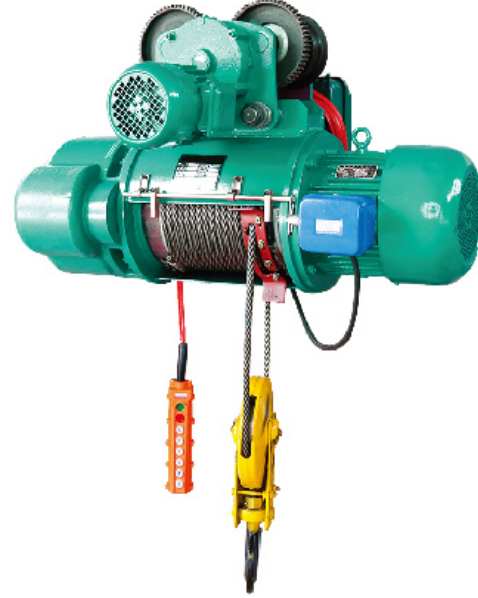

起重量 Hoisting capacity (T)	起升高度 Lifting height (m)	起升速度 Lifting speed (m/min)	运行速度 Running speed (m/min)	电源电压 Supply voltage (V/Hz)	接合次数 Num ber of junctions	钢丝绳 wire rope 规格 Specifications	结构 structure	工字钢型号 I-beam type	最小曲率半径 Minimum radius of curvature	电动机 Electric moto					
										主起升 Rise of Lord	副起升 Secondary Rise	运行 Move	功率 Power	转速 Speed	功率 Power
0.5	6.9/12/18	8/0.8	20/30	380/50	120	5.1-6×19+NF-1770-ZS	股1+6+12	16-28b	11.2	0.8	1380	0.2	1380	0.2	1380
1	6.9/12/18/24/30	8/0.8	20/30	380/50	120	7.4-6×37+NF-1770-I-S	股1+6+12+18	16-28b	11.2/1.8/2.5/3.3	1.5	1380	0.2	1380	0.2	1380
2	6.9/12/18/24/30	8/0.8	20/30	380/50	120	11-6×37+NF-1670-ZS	股1+6+12+18	20a-32c	1.2/1.5/2.2/5/3.5	3.0	1380	0.4	1380	0.4	1380
3	6.9/12/18/24/30	8/0.8	20/30	380/50	120	13-6×37+NF-1670-I-ZS	股1+6+12+18	20a-45c	1.2/1.5/2.2/5/3.5	1.5	1380	0.8	1380	0.4	1380
5	6.9/12/18/24/30	8/0.8	20/30	380/50	120	15-6×37+NF-1670-I-ZS	股1+6+12+18	28a-63c	1.5/2.5/3.4	7.5	1400	0.8	1380	0.8	1380
10	6.9/12/18/24/30	7/0.7	20/30	380/50	120	15-6×37+NF-1670-I-ZS	股1+6+12+18	28a-63c	2.5/3.3/5.4/5.6/7.2	13	1400	1.5	1380	0.8	1380

多功能电动提升机 Multi-function Electric Hoist

多功能电动提升机，采用锥形转子电动机和普通电动机为动力，与减速机结构组合带动卷筒，达到升降运转。多功能电动提升机具有制动速度快，体积小，重量轻，结构紧凑，使用安装方便，应用范围广，维修简便的特点。具有电动葫芦和卷扬机的主要功能。

Multi-functional electric hoist, using conical rotor motor and ordinary motor as the power, and gearbox structure combined drive drum, up and down operation. The multi-function electric hoist has the characteristics of fast braking speed, small volume, light weight, compact structure, convenient use and installation, wide application and easy maintenance. It has the main function of electric hoist and hoist.



产品型号 Product model	使用方式 Usage mode	额定电压 Rated voltage (V)	功率 Power (W)	额定起重量 Rated load weight (Kg)	起升速度 Lifting speed (m/min)	起升高度 Lifting altitude (m)	钢丝绳直径 Wire rope diameter (mm)	净重 N.W (kg)
300-600	单绳	220	0.6	300	16	30-60	5	34
	双绳			600	8			
500-1000	单绳	220	1.1	500	14	30-100	6	49
	双绳			1000	7			
500-1000	单绳	380	1.5	500	16	30-100	6	55
	双绳			1000	8			
750-1500	单绳	380	1.5	750	16	30-100	7.7	65
	双绳			1500	8			
1000-2000	单绳	380	3.0	1000	16	30-100	11	80
	双绳			2000	8			
400-800	单绳	220	1.6	400	14	30-60	6	40
	双绳			600	7			

注：净重以30米绳为准。其它规格也可订做。
Note: The net weight is 30m rope. Other specifications can also be customized.

电动卷扬机 Electric Hoist

卷扬机由电动机、联轴器、制动器、减速器和卷筒等部件共同安装在机架上而组成。本款卷扬机即使在提升高度较高，工作强度较大的情况下，其速度性能表现也足够优秀。此外，如遇安装敏感材料或需要低速的情况，卷扬机可以调节为较小的起升速度。卷扬机可以单独使用，也可以作为起重机械、道路施工或矿井绞车的组成部分，具有操作简单、绳索耐用、易于移动等优点，主要用于拖拽或平移物料，可广泛用于建筑、水利、林业、采矿、港口等领域。

Electric winch is composed of electric motor, couplings, brakes, gearbox and drum, jointly mounted on the frame. For the case of lifting height and large work of loading frequently, which has good speed performance and make empty hook decline rapidly. Besides, using a smaller speed for installation seated or sensitive materials. Hoist can be used alone, also can be used as a component of lifting machinery, road construction or mine hoist, which widely used with simple operation, roping large, easy displacement and mainly used for drag down or flat of materials in construction, water conservancy, forestry, mining, port and so on.

电动卷扬机使用注意事项：

- 1、筒上的钢丝绳应排列整齐，如发现重叠和斜绕时，应停机重新排列。严禁在转动中用手、脚拉踩钢丝绳。钢丝绳不许完全放出，少应保留三圈。
- 2、钢丝绳不许打结、扭绕，在一个节距内断线超过10%时，应予更换。运送物放下。
- 3、作业完毕、应将料盘落地、关锁电箱。
- 4、严禁超载使用。即超过大承载吨数。

Attention to the use of electric hoists:

1. wire rope on the cylinder should be arranged neatly, if overlapping and oblique winding is found, it should stop and rearrange. It is strictly forbidden to step on the wire rope with hands and feet in the rotation. Wire rope should not be fully released, less should be retained three laps.
2. the wire rope is not allowed to knot, twist around, in a pitch break more than 10%, should be replaced. Drop the delivery.
3. At the end of the operation, the tray shall be landed and the electric box shall be closed.
4. Overloading is strictly prohibited. that is, exceeding the large bearing tonnage.



产品型号 Product model	使用方式 Usage mode	额定电压 Rated voltage (V)	功率 Power (W)	额定起重量 Rated load weight (T)	起升高度 Lifting height (m)	起升速度 Lifting speed (m/min)	裸机重量 Naked machine weight (Kg)	钢丝绳直径 Wire rope diameter (mm)	槽钢型号 Channel steel model	包装尺寸 Package dimension L*W*H (cm)
1T	单绳 Single rope	380	1.5	0.5	30-100	16	80	7.7	8	76×24×40
	双绳 Double rope			1	30-100	8				
2T	单绳 Single rope	380	3	1	30-100	16	140	11	10	85×24×54
	双绳 Double rope			2	30-100	8				
3T	单绳 Single rope	380	4.5	1.5	30-100	16	170	13	10	94×24×57
	双绳 Double rope			3	30-100	8				
4T	单绳 Single rope	380	7.5	2.5	30-100	16	250	15	10	106×24×63
	双绳 Double rope			3	30-100	8				

铝壳提升机 KCD Electric Wire Rope Hoist



KCD electric winch is referred to the class of inexpensive semi industrial winches and is recommended for household and industrial facilities applications for low-level operations. Not designed for regular load-handling operations in high-rise buildings. Advantages: moderate price, small dimensions and weight, drum rope capacity up to 100 m, possibility of power supply from 220V mains (some models).

Multifunctional motor hoist

Capacity: 0.5T-1.5T
It can be installed air and ground.
Highest lifting
Lifting Height: 30-100M
Hook Type: Single/ Double
Aluminum case, very light

型号 Model	使用方法 Usage method	额定电压 Rated voltage (V)	功率 Power (KW)	容量 Capacity (kg)	起升速度 Lifting speed (m/min)	起升高度 Lifting height (m)	钢丝绳直径 Wire rope diameter (mm)	重量 Weight (Kg)
KM300-600	单钩 Single hook	380	0.6	300	14	30-60	5	32
	双钩 Double hook			600	7			
KM400-800	单钩 Single hook	380	1.8	400	10	30-100	6	34
	双钩 Double hook			800	5			
KM500-1000	单钩 Single hook	380	2.2	500	10	30-100	6	35
	双钩 Double hook			1000	5			
KM500-1000	单钩 Single hook	380	1.5	500	14	30-100	6	48
	双钩 Double hook			1000	7			
KM500-1000	单钩 Single hook	380	1.5	500	24	30-100	6	48
	双钩 Double hook			1000	12			
KM750-1500	单钩 Single hook	380	1.5	750	16	30-100	7.7	70
	双钩 Double hook			1500	8			
KM1000-2000	单钩 Single hook	380	3.0	1000	16	30-100	11	135
	双钩 Double hook			2000	8			



新型二代提升机
New second generation hoist

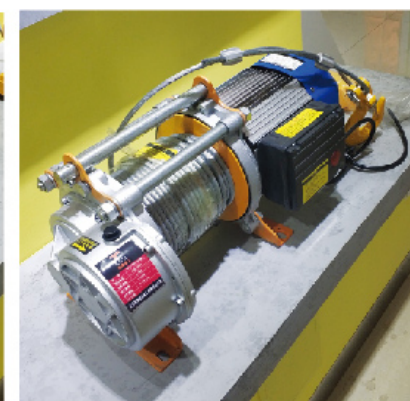

1.5T单相多功能电动提升机
1.5T Single-phase multifunctional electric hoist

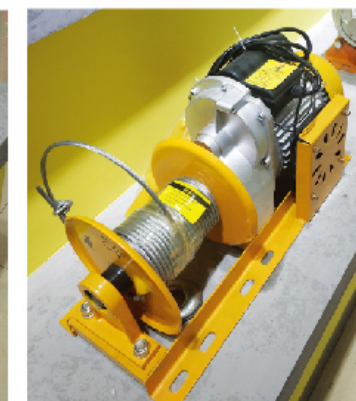

新型室外吊运机静音王
Voice King New Outdoor Hoist

微型电动葫芦系列 Mini Electric Hoist Series

微型电动葫芦，适用于各种场合吊卸小件货物。结构简单、安装方便、小巧玲珑，采用单相电作动力源。广泛应用于现代化工业生产线、流水线、仓库、商场、饭店、家庭、装修和搬运、空间较狭窄的场所等。也是立柱式、墙壁式悬臂起重机的配套产品。

Mini electric hoist, suitable for lifting and unloading small goods in various occasions. Simple structure, easy installation, small and exquisite, single phase electric power source. Widely used in modern industrial production lines, assembly lines, warehouses, shopping malls, restaurants, homes, decoration and handling, space narrower places and so on. Is also fixed column type, wall type cantilever crane matching products.



安装图
Drawing for fixation

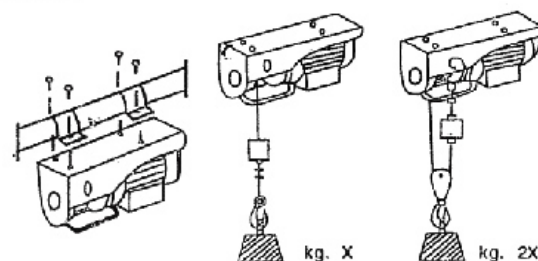

钢丝绳缠绕方法
Twined manner of rope

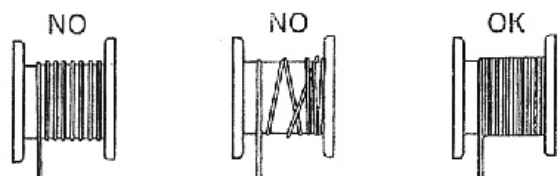

产品型号 Product model	使用方式 Usage mode	额定起重量 Rated load weight (kg)	起升高度 Lifting altitude (m)	起升速度 Lifting speed (m/min)	输入功率 Interiorinput power (W)	电压 voltage (V)	频率 Frequency (Hz)	数量 Quantity	包装尺寸 Packing Size (cm)	毛重/净重 GW/NW (kg)
PA200	单钩 Single Hook	100/200	12/6	10/5	550	110/220	50/60	2	38×32×25	24/22
PA250	双钩 Double Hook	125/250	12/6	10/5	550	110/220	50/60	2	38×32×25	25/23
PA300	单钩 Single Hook	150/300	12/6	10/5	600	110/220	50/60	2	38×32×25	26/24
PA400	双钩 Double Hook	200/400	12/6	10/5	980	110/220	50/60	2	45×33×27	34/33
PA500	单钩 Single Hook	250/500	12/6	10/5	1020	110/220	50/60	2	45×33×27	35/34
PA600	双钩 Double Hook	300/600	12/6	10/5	1250	110/220	50/60	2	45×33×27	36/35
PA800	单钩 Single Hook	400/800	12/6	10/5	1500	110/220	50/60	2	45×33×27	38/37
PA999	双钩 Double Hook	500/1000	12/6	8/4	1800	110/220	50/60	1	54×25×32	33.7/32.7

便携电动葫芦 Portable Electric Hoist

- 1、电机的综合性能良好，保障使用的安全性和可靠性，降低危险发生几率。
- 2、整个机体的结构很简单。方便于进行安装、拆卸、检修，有很好的可维护性。
- 3、净空高度佳，有效的节省了空间，不受空间狭小的限制。
- 4、三合一传动技术提供优良的性能，优质合金钢制造的起升减速机，能够实现三级减速，运行十分平稳、有很久的使用寿命、性能可靠，避免了CD葫芦中间轴长距离传动的许多缺点。
- 5、更多的独特创新，外型新颖、美观，结构精致轻巧。

1. The motor has excellent comprehensive performance, ensuring safety, reliability during use reducing the likelihood of accidents.
2. The overall structure of the machine is simple, making it easy to install, disassemble, maintain, providing good maintainability.
3. The high clearance height is advantageous, effectively saving space not being restricted by small spaces.
4. The three-in-one transmission technology provides excellent performance, the hoist reducer made of high-quality alloy steel can achieve three-stage deceleration, with smooth operation, long service life, reliable performance, avoiding many disadvantages of long-distance transmission of the intermediate shaft in the CD hoist.
5. More unique innovations, with a novel and beautiful appearance, exquisite, lightweight structure.



额定载荷 Rated Capacity	500kg	300kg	200kg
电压 Power Voltage (V, Hz)	110V/220V/50Hz	110V/220V/50Hz	110V/220V/50Hz
提升速度 Lifting speed (m/min)	5	5	5
起升高度 Traction distance(m)	7.6	11.8	19
钢丝绳高度 Wire rope(mm)	6×7.6	4.8×11.8	4×19
功率 Power (W)	1500	1500	1500
包装尺寸 Package dimensions(cm)	39×32×25	38×32×25	38×32×25

小金刚 Little King Kong

- ◆ 小金刚产品分线控款和遥控款
- ◆ 线控款手柄线长6米，遥控款遥控可控范围150米
- ◆ 220V电压 体积小 重量轻 携带方便
- ◆ Small King Kong products branch control and remote control
- ◆ Line control handle line length 6 meters, remote control remote control range 150 meters
- ◆ 220V voltage Small size In light weight Easy to carry

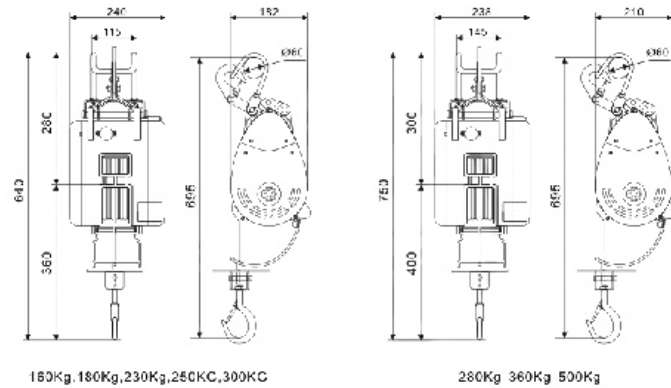

手拉葫芦/手扳葫芦系列 Chain Block / Lever Hoist Series

HSZ-80A/B系列手拉葫芦 HSZ-80A/B Series Chain Block

HSZ-80A/B系列手拉葫芦是我厂最新推出的，设计先进，质量可靠，采用了等边三角弧形，使产品造型更加新颖美观。可与单轨车配套使用组成起重运输小车，用于单轨架空运输，或用于手动单梁起重机和悬臂式起重机上。

HSZ-80A/B series hand hoist is the latest launched by our factory, advanced design, reliable quality, the use of Equilateral triangular arc, novel and beautiful product shape. Can be used with monorail car supporting the formation of crane transport car, used for monorail overhead transport, or for manual single beam crane and cantilever crane.

HSZ-80A/B系列手拉葫芦主要特点:

- ◆ 采用Z(重)级工作级别，性能可靠，经久耐用。
- ◆ 采用800Mpa高强度起重链条，安全系数高，使用寿命长。
- ◆ 结构紧凑合理，外形美观新颖。
- ◆ 传动平稳，效率高，手拉力小。
- ◆ 双棘爪、双导轮结构，更加安全可靠。
- ◆ 体积小，重量轻，使用简便。

HSZ-80A/B series hand hoist main characteristic:

- ◆ Z(heavy) grade work level, reliable performance, durable.
- ◆ 800Mpa high strength lifting chain, high safety factor, long service life.
- ◆ Compact and reasonable structure, beautiful and novel appearance.
- ◆ Smooth transmission, high efficiency, small hand tension.
- ◆ Double pawl, double regulating wheel structure, more safe and reliable.
- ◆ Small size, light weight, easy to use.

规格型号 Specifications model	额定起重量 Rated hoisting capacity (tons)	标准起重高度 Standard Lifting Height (m)	试验载荷 Test load (KN)	最大拉力 Maxim um pull (N)	起重链条行数 Falls of chain	起重链条直径 Lifting chain diameter (mm)	净重 N.W (kg)	包装尺寸 Packing measurement (cm)	每增加一米增加重量 Added weight per 1m lift (kg)
HSZ-0.5	0.5	3	7.5	225	1	5	7	22×15×18	1.5
HSZ-1	1	3	15	300	1	6	11.5	25×18×18.5	1.8
HSZ-1.5	1.5	3	22.5	310	1	7.1	14	30×20×20	2.1
HSZ-2	2	3	30	310	1	8	20	29.5×22.5×22.5	2.3
HSZ-2S	2	3	30	300	2	6	15.3	29.5×22.5×22.5	3.6
HSZ-3	3	3	45	350	2	7.1	21	34×23.5×18.5	4.2
HSZ-5	5	3	75	400	2	9	38	47.5×28.5×22.5	4.6
HSZ-10	10	3	150	410	4	9	70	49.5×46.5×25	9.8
HSZ-20	20	3	300	410×2	8	9	162	64×38×64	19.6
HSZ-30	30	3	450	410×2	12	10	230	72×50×68	28.3

注：除列表外，在12米以内各起重高度，均可订货。

Note: Except the list, within 12 meters of each lifting height, can be ordered.

HS-C型系列手拉葫芦 HS-C Series Chain Block

HS-C型系列手拉葫芦是公司在HSZ型手拉葫芦的基础上融合世界先进技术改良后产品，除具有HSZ型手拉葫芦的传统特点外，更是一种手拉力小，安全系数高，外形美观，实用性更高的手拉葫芦。

HS-C series chain block is the company in the HSZ type hand chain block on the basis of the integration of the world's advanced technology improved products, in addition to the traditional characteristics of the HSZ type hand chain block, but also a small chain block, high safety factor, beautiful appearance, more practical hand chain block.

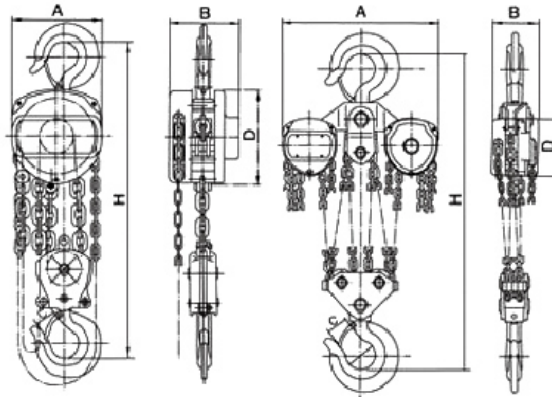

规格型号 Specifications model	额定起重量 Rated hoisting capacity (t)	标准起重高度 Standard Lifting Height (m)	试验载荷 Test load (t)	两钩间最小距离 Minimum distance between two hooks (mm)	满载时手链拉力 Chainpull to lift full load (N)	起重链条行数 Falls of chain	起重链条直径 Lifting chain diameter (mm)	净重 N.W (kg)	装箱毛重 G.W (kg)	包装尺寸 Packing measurement (cm)	每增加一米增加重量 Added weight per 1m lift (kg)
HSZ-0.5	0.5	2.5	0.63	265	221	1	6	8	10	28×21×17	1.7
HSZ-1	1	2.5	1.25	306	304	1	6	10	13	30×24×18	1.7
HSZ-1.5	1.5	2.5	2	368	343	1	8	16	20	34×29×20	2.3
HSZ-2	2	2.5	2.5	444	314	2	6	14	17	33×25×19	2.5
HSZ-3	3	3	4	486	343	2	8	24	28	38×30×20	3.7
HSZ-5	5	3	6.3	616	383	2	10	36	45	45×35×24	5.3
HSZ-10	10	3	12.5	700	392	4	10	68	83	62×50×28	9.7
HSZ-20	20	3	25	1000	392	8	10	150	194	70×45×75	19.4

注：除列表外，在12米以内各起重高度，均可订货。
Note: Except the list, within 12 meters of each lifting height, can be ordered.

HSZ型系列手拉葫芦 HSZ Series Chain Block

HSZ型系列手拉葫芦是一种使用广泛，携带方便的手动起重机械，可用于工业农业、建筑业、矿业等的机械安装、货物起吊、车辆装卸等，尤其适用于露天及无电源作业。

HSZ型系列手拉葫芦与各型手拉单轨行车配套使用组成手拉起重运输小车，适用于单轨架空运输，手动单梁桥式起重机和悬臂式起重机上。

HSZ series chain block is a widely used, easy to carry manual lifting machinery, can be used in industrial agriculture, construction, mining and other mechanical installation, cargo lifting, vehicle loading and unloading, especially for open air and no power operation.

HSZ series chain block and each type of hand-pulling monorail carriage are used together to form a hand-pulling which is suitable for monorail overhead transportation, manual single-beam bridge crane and cantilever crane.

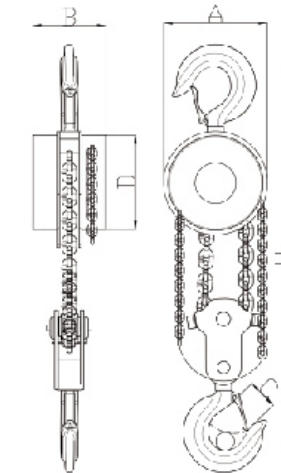

规格型号 Specifications model	额定起重量 Rated hoisting capacity (t)	标准起重高度 Standard Lifting Height (m)	试验载荷 Test load (t)	两钩间最小距离 Minimum distance between two hooks (mm)	满载时手链拉力 Chainpull to lift full load (N)	起重链条行数 Number of lifting chains	起重链条直径 Lifting chain diameter (mm)	净重 N.W (kg)	装箱毛重 G.W (kg)	包装尺寸 Packing measurement (cm)	每增加一米增加重量 Added weight per 1m lift (kg)
HSZ-0.5	0.5	2.5	0.63	270	225	1	6	9.5	12	28×21×17	1.7
HSZ-1	1	2.5	1.25	270	309	1	6	10	13	30×24×18	1.7
HSZ-1.5	1.5	2.5	2	368	343	1	8	16	20	34×29×20	2.3
HSZ-2	2	2.5	2.5	440	314	2	6	14	17	33×25×19	2.5
HSZ-3	3	3	4	486	343	2	8	24	28	38×30×20	3.7
HSZ-5	5	3	6.3	616	383	2	10	36	45	45×35×24	5.3
HSZ-10	10	3	12.5	700	392	4	10	68	83	62×50×28	9.7
HSZ-20	20	3	25	1000	392	8	10	155	193	70×45×75	19.4

注：除列表外，在12米以内各起重高度，均可订货。
Note: Except the list, within 12 meters of each lifting height, can be ordered.

HSZ-A型系列手拉葫芦 HSZ-A Series Chain Block

产品特点：1、外罩壳加厚设计，增加凸筋工艺，耐撞击，有效保护内部传动机构。2、手轮罩采用卷边工艺，增加强度，避免卡链和很大的噪音。3、齿轮采用优质合金钢精密锻造加工，并经过热处理后经久耐用，体现高传动效率。4、吊钩采用优质合金材料，经特殊热处理，提高安全警示性，超载时不断裂。

Product features: 1. outer cover shell thickening design, increase the convex reinforcement process, impact resistance, effective protection of internal transmission mechanism. 2. hand wheel cover adopts the crimping process to increase the strength and avoid the clasp and great noise. 3. gear adopts high quality alloy steel precision forging processing, and after heat treatment durable, reflect high transmission efficiency. 4. hook adopts high quality alloy material, after special heat treatment, improve safety warning, and do not break when overload.

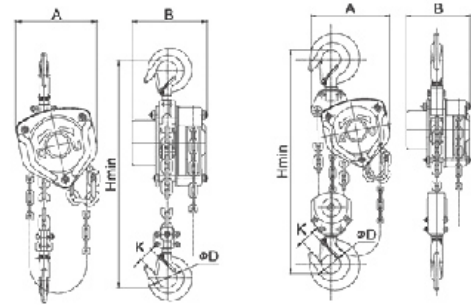

规格型号 Specifications model	额定起重量 Rated hoisting capacity (tons)	标准起重高度 Standard Lifting Height (m)	试验载荷 Test load (KN)	满载时手链拉力 Chainpull to lift full load (N)	起重链条行数 Number of lifting chains	起重链条直径 Lifting chain diameter (mm)	Hmin (mm)	净重 N.W (kg)	包装尺寸 Packing measurement (cm)	每增加一米增加重量 Added weight per 1m lift (kg)
HSZ-A-0.5	0.5	3	6.1	200	1	6×18	300	8.36	22×15×20	1.6
HSZ-A-1	1	3	12.3	320	1	6×18	340	10.6	23×18×20	1.6
HSZ-A-1.5	1.5	3	18.4	360	1	8×24	410	15.2	28×21×24	2.2
HSZ-A-2	2	3	24.5	365	1	8×24	440	17.7	28×21×24	2.2
HSZ-A-3	3	3	36.8	385	2	10×30	500	24.2	32×21×26	3.6
HSZ-A-5	5	3	61.1	435	2	10×30	610	35.8	40×21×26	5.2
HSZ-A-10	10	3	122.5	435	4	10×30	800	77.7	50×41×21	9.5
HSZ-A-20	20	3	235.5	435×2	8	10×30	1000	162.2	64×38×64	19
HSZ-A-30	30	3	267.5	435×2	12	10×30	1380	238.5	72×50×68	27.7
HSZ-A-50	50	3	612.5	435×2	22	10×30	2578	1092	110×110×130	49.4

注：除列表外，在12米以内各起重高度，均可订货。
Note: Except the list, within 12 meters of each lifting height, can be ordered.

VT系列手拉葫芦 VT Series Chain Block

- 1、双刹车安全有保障。
- 2、高品质双导链轮光滑不卡链。
- 3、淬火精炼，锰钢链条。
- 4、合金钢加厚罩壳，抗磨损能力强，保护内部结构安全运行。

1. Double brake safety is guaranteed.
2. High quality double guide sprocket smooth non-stuck chain.
3. Quenched refined manganese steel chain.
4. Alloy steel thickened cover, strong anti-wear ability, protect the internal structure safe operation.



规格型号 Specifications model	额定起重量 Rated hoisting capacity (tons)	标准起重高度 Standard Lifting Height (m)	试验载荷 Test load (KN)	满载时手链拉力 Chainpull to lift full load (N)	起重链条行数 Number of lifting chains	起重链条直径 Lifting chain diameter (mm)	Hmin (mm)	净重 N.W (kg)	包装尺寸 Packing measurement (cm)	每增加一米增加重量 Added weight per 1m lift (kg)
HSZ-V-0.5	0.5	2.5	6.3	231	1	6	300	7	20×16×19	1.5
HSZ-V-1	1	2.5	12.5	309	1	6	340	10.6	23×18×20	1.8
HSZ-V-1.5	1.5	2.5	18.8	320	1	8	410	17	27×22×22	2.2
HSZ-V-2	2	3	25	320	1	8	440	18	27×22×22	2.2
HSZ-V-3	3	3	37.5	360	2	8	500	22	31×23×21	3.8
HSZ-V-5	5	3	62.5	414	2	10	610	40	42×28×24	5.4
HSZ-V-10	10	3	125	420	4	10	800	70	54×49×28	9.8
HSZ-V-20	20	3	250	420×2	8	10	1000	162	78×72×34	19.6
HSZ-V-30	30	3	375	420×2	12	10	1380	228	88×78×42	28.3
HSZ-V-50	50	3	625	420×2	22	10	2578	1085	160×130×75	50

注：除列表外，在12米以内各起重高度，均可订货。
Note: Except the list, within 12 meters of each lifting height, can be ordered.

HSH型手扳葫芦 HSH Type Lever Hoist

HSH型系列手扳葫芦采用新设计，具有快速调整下吊钩位置的功能，造型新颖，款式别致，机体美观，制动性能良好，工作效率更高，也一直是国内外畅销的优质名牌产品，更是你可靠的帮手。

HSH series lever hoist adopts the new design, has the function of adjusting the hook position quickly, the shape is novel, the style is chic, the body is beautiful, the brake performance is good, the work efficiency is higher, also has been the domestic and foreign best-selling high quality famous brand product, is your reliable helper.



- ◆ 重量轻，体积小，手柄操作力小。
- ◆ 标准配置高强度合金钢起重链条。
- ◆ 经过专门热处理的锻造吊钩，强度高，使用寿命长。
- ◆ 可根据要求配置不同的起重高度。
- ◆ Light weight, small volume and small handle operating force.
- ◆ Standard configuration high strength alloy steel lifting chain.
- ◆ Forging hooks after special heat treatment with high strength and long service life.
- ◆ Different lifting heights can be configured according to requirements.

规格型号 Specifications model	额定起重量 Rated hoisting capacity (tons)	标准起重高度 Standard Lifting Height (m)	试验载荷 Test load (KN)	满载时手扳力 Hand wrench at full load (N)	起重链条行数 Number of lifting chains	起重链条直径 Lifting chain diameter (mm)	净重 N.W (kg)	包装尺寸 Packing measurement (cm)	每增加一米增加重量 Added weight per 1m lift (kg)
HSH-0.5	0.5	1.5	7.5	340	1	5	4	33×12×9	0.54
HSH-0.75	0.75	1.5	11.25	140	1	6	7	33×16×13	0.8
HSH-1	1	1.5	15	185	1	6	7	33×16×13	0.8
HSH-1.5	1.5	1.5	22.5	234	1	7.1	11	43×18.5×16	1.1
HSH-2	2	1.5	30	251	1	8	15.5	44×19×17	1.4
HSH-3	3	1.5	45	362	1	10	20	50×20×18	2.2
HSH-6	6	1.5	90	362	2	10	28	53×21×21	4.4
HSH-9	9	1.5	112.5	360	3	10	47	82×32×21.5	6.6

VT型手扳葫芦 VT Type Lever Hoist

VT型系列手扳葫芦是多模块结构，使用更安全；重量轻，体积小，手柄操作力小；

G80合金钢起重链条；

锰钢齿轮组，结构紧凑；

热处理的锻造吊钩，强度高，具有超重延展性。

支持定制，可根据客户要求，配置不同的提升高度。

广泛地应用于造船、电力、运输、建筑、矿山、邮电等行业的设备安装，物品起吊、机件牵拉等。

VT series of lever hoist is multi-module structure, more safe to use;

light weight, small volume, small handle operation force;

G80 alloy steel lifting chain;

manganese steel gear set, compact structure;

heat forging hook, high strength, with overweight ductility.

Support customization, can be based on customer requirements, configuration of different elevations.

Widely used in shipbuilding, electricity, transportation, construction, mining, post and telecommunications and other industries of equipment installation, goods lifting, machine parts pull.



型号 Model	0.75	1.5	3	6
起重量 Hoisting capacity (t)	0.75	1.5	3	6
标准起重高度 Standard lifting height (m)	1.5	1.5	1.5	1.5
试验载荷 Test load (t)	9.2	18.4	36.8	73.5
满载时手扳力 Hand wrench at full load (N)	148	216	336	345
起重链条行数 Number of lifting links	1	1	1	2
起重链条直径 Lifting chain diameter (mm)	6.3	7.1	9	9
净重 Net weight (kg)	6.6	11.65	21.1	23.7

吊装带/拉紧器系列

High Strength Webbing Sling EA & EB Series

- ◆ Product standard: JB /T8521.2-2007/ EN 1492-2.
 - ◆ Raw material (sleeve/core) : high strength and low shrinkage polyester fiber filament.
 - ◆ Process control: implement standard requirements.
 - ◆ Size (length) : See relevant standards or customer requirements for details.
 - ◆ Sling color: dyeing according to the color requirements of different specifications.
 - ◆ Breaking force: standard 6 WLL (6 times limit working load).
 - ◆ Light and soft, easy to use in small space; Add protective sleeve or protective device (Angle guard, etc.); according to the use environment; The ambient temperature is -40 °C to 100 °C .
- [Note: According to customer needs, we can research, develop and manufacture breaking force: 4WLL/5WLL/7WLL round sling products]



极限工作载荷 Extreme Working Load WLL(T)

规格 Code (T)	单条吊带载荷极限 WLL with 1 webbing sling				双条吊带载荷极限 WLL with 2 webbing sling				3条/4条吊带载荷极限 WLL with 3/4 webbing sling			
	垂直提升		扼圈式提升		垂直提升		扼圈式提升		垂直提升		扼圈式提升	
	颜色 Color	Straight	Choker	β	Straight	Choker	Straight	Choker	Straight	Choker	Straight	Choker
	M=1	M=0.8	M=2	M=1.4	M=1	M=1.4	M=1.1	M=1	M=0.8	M=2.1	M=1.5	
1.0 紫色 Purple	1.0	0.8	2.0	1.4	1.0	1.4	1.1	1.0	0.8	2.1	1.5	
2.0 绿色 Green	2.0	1.6	4.0	2.8	2.0	2.8	2.2	2.0	1.6	4.2	3.0	
3.0 黄色 Yellow	3.0	2.4	6.0	4.2	3.0	4.2	3.3	3.0	2.4	6.3	4.5	
4.0 灰色 Grey	4.0	3.2	8.0	5.6	4.0	5.6	4.4	4.0	3.2	8.4	6.0	
5.0 红色 Red	5.0	4.0	10.0	7.0	5.0	7.0	5.5	5.0	4.0	10.5	7.5	
6.0 棕色 Brown	6.0	4.8	12.0	8.4	6.0	8.4	6.6	6.0	4.8	12.6	9.0	
8.0 蓝色 Blue	8.0	6.4	16.0	11.2	8.0	11.2	8.8	8.0	6.4	16.8	12.0	
10.0 橙色 Orange	10.0	8.0	20.0	14.0	10.0	14.0	11.0	10.0	8.0	21.0	15.0	
12.0 橙色 Orange	12.0	9.6	24.0	16.8	12.0	16.8	13.2	12.0	9.6	25.2	18.0	
15.0 橙色 Orange	15.0	12.0	30.0	21.0	15.0	21.0	16.5	15.0	12.0	31.5	22.5	
20.0 橙色 Orange	20.0	16.0	40.0	28.0	20.0	28.0	22.0	20.0	16.0	42.0	30.0	
25.0 橙色 Orange	25.0	20.0	50.0	35.0	25.0	35.0	27.5	25.0	20.0	52.5	37.5	
30.0 橙色 Orange	30.0	24.0	60.0	42.0	30.0	42.0	33.0	30.0	24.0	63.0	45.0	
40.0 橙色 Orange	40.0	32.0	80.0	50.0	40.0	50.0	44.0	40.0	32.0	84.0	60.0	
50.0 橙色 Orange	50.0	40.0	100.0	70.0	50.0	70.0	55.0	50.0	40.0	105.0	75.0	
60.0 橙色 Orange	60.0	48.0	120.0	84.0	60.0	84.0	66.0	60.0	48.0	126.0	90.0	
80.0 橙色 Orange	80.0	64.0	160.0	112.0	80.0	112.0	88.0	80.0	64.0	168.0	120.0	
100.0 橙色 Orange	100.0	80.0	200.0	140.0	100.0	140.0	110.0	100.0	80.0	210.0	150.0	

[注: M=对称承载的系数, 吊装带或吊装带零件的安装公差: 垂直方向为6°。]
[Note: M = coefficient of symmetrical bearing, installation tolerance of hoisting belt or hoisting belt parts: vertical direction is 6° .]

栓紧器 Fastener

- ◆ 可根据实际需要配备未配件 (双排钩、三角环等)。
 - ◆ 请注意: 严禁用于起吊货物用、严禁超载使用。
 - ◆ 标准长度为8米, 可制作1m-50m, 使用范围: -40℃-100℃。
 - ◆ 仅适用没有破损的栓紧器, 标签可以清晰的表明能力。
 - ◆ 不要将织带打结使用。
 - ◆ 可使用保护套使织物远离锋利棱角, 免受磨损或切割。
 - ◆ 避免扭曲、拧绞栓紧器。
 - ◆ 不要将物体放置在栓紧器上, 这样会导致伤害。
- ◆ Can be equipped with final accessories according to the actual needs (double row hook, triangle ring, etc.).
 - ◆ Please note: It is strictly prohibited to use for lifting goods or overload.
 - ◆ The standard length is 8 meters, 1m to 50m can be made, range of use :-40C-100C.
 - ◆ Applicable only to unbroken latches, label can clearly indicate capacity.
 - ◆ Do not use the webbing in knots.
 - ◆ Protective covers can be used to keep the fabric away from sharp edges, fraying or cutting.
 - ◆ Avoid twisting and twisting the leaser.
 - ◆ Do not place objects on leashes as this can cause injury.

SJ01型 Type SJ01



规格 Size	破断载荷 Break load (kg)	适用带宽 Applicable bandwidth (mm)	总体长度 Total length (m)	成套重量 Weight Package (kg)
SJ01-01	2000	25	8	1.45
SJ01-02	5000	50	8	3.90
SJ01-03	8000	75	8	18.5

SJ03型 Type SJ03



规格 Size	破断载荷 Break load (kg)	适用带宽 Applicable bandwidth (mm)	总体长度 Total length (m)	成套重量 Weight Package (kg)
SJ03-01	2000	25	8	1.45
SJ03-02	5000	50	8	3.90
SJ03-03	8000	75	8	18.5

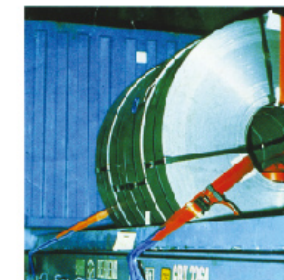

SJ02型 Type SJ02



规格 Size	破断载荷 Break load (kg)	适用带宽 Applicable bandwidth (mm)	总体长度 Total length (m)	成套重量 Weight Package (kg)
SJ02-01	2000	25	8	1.45
SJ02-02	5000	50	8	3.90
SJ02-03	8000	75	8	18.5

SJ04型 Type SJ04



规格 Size	破断载荷 Break load (kg)	适用带宽 Applicable bandwidth (mm)	总体长度 Total length (m)	成套重量 Weight Package (kg)
SJ04-01	2000	25	8	1.45
SJ04-02	5000	50	8	3.90
SJ04-03	8000	75	8	18.5

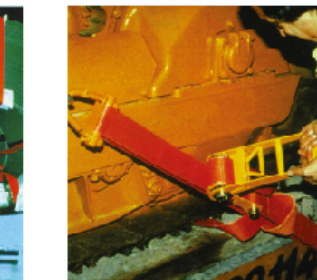

其他系列

Ungroup Series

单轨电动行车 Monorail Electric Trolley

单轨电动行车以电动机驱动，行车与工字钢的轨道下缘处，配以电动葫芦或手拉葫芦便可组成桥式，单梁或悬臂式微型起重机，广泛适用于工厂、矿山、码头、仓库、机械加工、注塑、压铸、冲压、装卸磨具、建筑工地等用于安装机器设备，吊运货物的场合，其配套的起重采用220V单项电源，适用性广泛。

A single-beam or cantilever mini-crane is widely used in factories, mines, wharves, warehouses, machining, injection molding, die-casting, stamping, loading and unloading grinding tools, construction sites and other occasions for the installation of machinery and equipment, lifting goods, its supporting lifting using 220V single power supply, wide applicability.

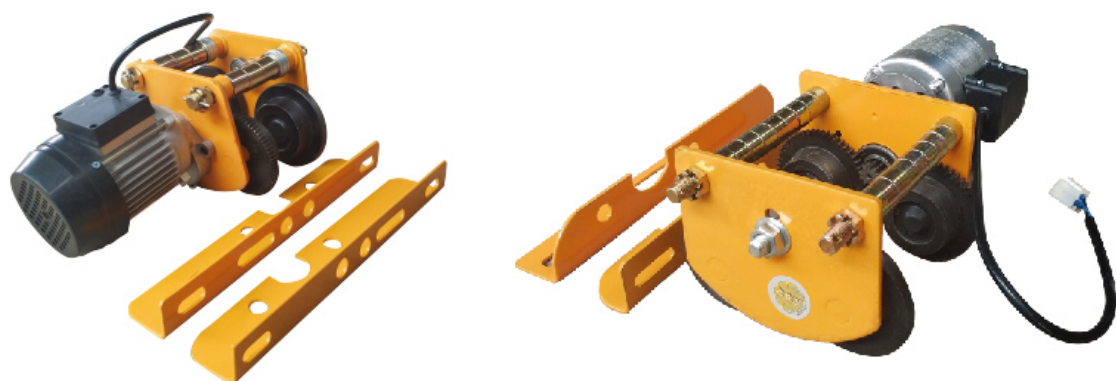

型号 Model	TD0.5	TD1
额定载荷 Rated load (t)	0.5	1
试验载荷 Test load (t)	0.6	1.2
标准运行高度 Standard operating height (m)	3	3
运行速度 Running speed (m/min)	16.4	16.4
电源电压 Supply voltage (V Hz)	AC220V 50Hz	AC220V 50Hz
电机功率 Motor power (W)	60	200
电机转速 Motor speed (r/min)	1400	1400
能通过的最小弯道半径 Minimum bend radius that can pass (m)	1	1
工字钢号 I-steel	10-22	10-22
工字钢轨宽 I-beam Rail width (mm)	68-110	68-110
净重 N.W (kg)	8	19

单轨微型六轮电动行车 Monorail Mini Six-wheel Electric Trolley



型号 Model	0.5	1
额定载荷 Rated load (t)	0.5	1
试验载荷 Test load (t)	0.6	1.2
标准运行高度 Standard operating height (m)	3	3
运行速度 Running speed (m/min)	13	13
电源电压 Supply voltage (V Hz)	AC220V 50Hz	AC220V 50Hz
电机功率 Motor power (W)	60	200
电机转速 Motor speed (r/min)	1400	1400
能通过的最小弯道半径 Minimum bend radius that can pass (m)	1	1.5
工字钢号 I-steel	10-18	14-22
工字钢轨宽 I-beam Rail width (mm)	68-94	80-110
净重 N.W (kg)	14	17

单轨提升机行车 Monorail Trolley



额定载重量 Rated Load capacity (t)	额定功率 Power rating (Kw)	转速 Speed (r/min)	适用工字钢 Suitable for I-steel	轨宽范围 Track width range (mm)	行走速度 Speed of travel (m/min)	额定电压 Rated voltage (V)	净重 N.W (kg)
1	0.2	1380	10-18	68-94	20	380/220	17

单轨桃型手拉行车 Monorail Trolley

产品介绍:

- (1) 手推/手链单轨小车应与手拉葫芦、手扳葫芦或其它起重工具配套使用;
- (2) 安装于工字钢轨道的下翼缘上, 组成起重运输小车;
- (3) 手推/手链单轨小车内装有滚动轴承;
- (4) 具有传动效率高, 手推/拉力小。

注意事项:

- (1) 小车严禁超过额定载重量使用;
- (2) 小车在吊运重物时, 严禁任何人员在重物下行走或工作;
- (3) 小车在工作时, 如遇手推力/手拉力异常或发生其它故障, 应立即停止使用, 查明原因, 并排除故障。
- (4) 轴承应定期加注润滑脂, 同时认真检查紧固件有无松动。

Product description:

- (1) Hand-push/hand-chain monorail trolley shall be used in conjunction with hand-pulled hoist, hand-pulled hoist or other lifting tools;
- (2) Installed on the lower flange of the I-beam track to form a lifting trolley;
- (3) The hand-push/hand-chain monorail car is equipped with rolling bearings;
- (4) High transmission efficiency with small push/pull force.

Note:

- (1) It is strictly forbidden to use the trolley in excess of the rated deadweight;
- (2) It is strictly prohibited for any person to walk or work under heavy objects while lifting heavy objects;
- (3) When the trolley is in operation, if the hand thrust/hand pull force is abnormal or other malfunction occurs, it should be stopped immediately to find out the cause and troubleshoot.
- (4) The bearing should be greased regularly, and the fastener should be carefully checked for loosening.



单轨桃型手拉跑车
Monorail Peach Hand Trolley



单轨桃型手推跑车
Monorail Peach Hand Trolley

额定载重量 Rated Load capacity (t)	试验载荷 Test load (t)	能通过的最小弯道半径 Minimum bend radius that can pass (m)	推荐用工字钢 Recommended I-steel (mm)
0.5	0.625	1	68-94
1	1.25	1	68-100
2	2.5	1.1	94-124
3	3.75	1.3	116-140
5	6.25	1.4	142-180
10	12.5	1.7	142-180

单轨重型手拉行车 Monorail heavy hand Trolley



防撞单轨手拉行车
Anti-collision Manual Trolley



重型单轨手拉行车
Heavy Monorail Trolley

额定载重量 Rated Load capacity (t)	试验载荷 Test load (t)	能通过的最小弯道半径 Minimum bend radius that can pass (m)	推荐用工字钢 Recommended I-steel (mm)	净重 N.W (kg)
1	1.25	1	40-125	9
2	2.25	1.1	55-125	12
3	3.25	1.3	55-155	18
5	5.25	1.4	70-165	31

单轨重型手推行车 Monorail Heavy Hand Trolley

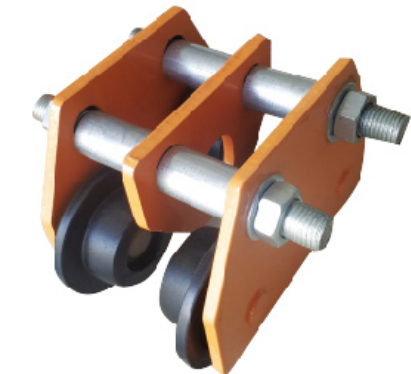

额定载重量 Rated Load capacity (t)	推荐用工字钢 Recommended I-steel (mm)	净重 N.W (kg)
0.5	68-94	4.8
1	68-100	7.7
2	94-124	12.8
3	100-140	24.5
5	124-180	43
10	142-180	88

搬运坦克车 Cargo Trolley

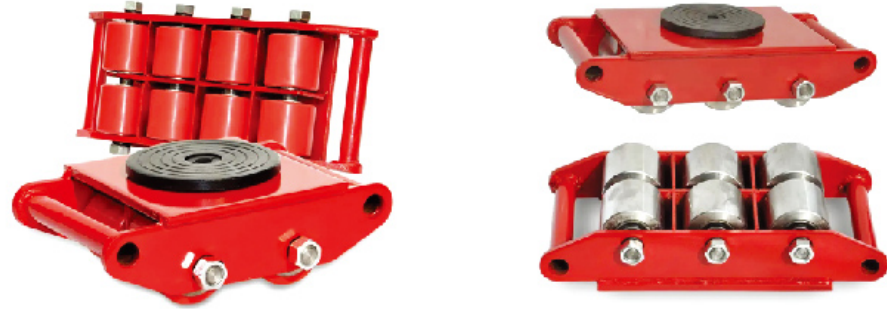

型号 Model	正常载荷 Normal Capacity	轮子数量 NO.of wheels	PU wheel Weight (kg)	Steel wheel Weight (kg)	设备尺寸 Size (cm)
CRA-6T	4	4	11.8	16	280×215×105
CRA-8T	6	6	16.8	23	380×215×105
CRA-12T	8	8	21.6	30	475×220×105
CRA-15T	12	9	24.1	33	380×330×105
CRA-18T	15	12	34	42	475×370×110
CRA-24T	20	16	46.5	56	490×390×110
CRA-32T	30	20	70	79	590×390×110
CRA-40T	36	25	80	90	590×480×110

搬运坦克车 Cargo Trolley



型号 Model	最大载荷 Max loading (t)	正常载荷 Normal Capacity (t)	轮子数量 NO.of wheels	PU wheel Weight (kg)	Steel wheel Weight (kg)	设备尺寸 Size (cm)
CRA-6T	6	4	4	12	16	310×195×110
CRA-8T	8	6	6	16.88	23	400×195×110
CRA-12T	12	8	8	22.1	31	450×280×110
CRA-15T	15	9	9	24.1	35	450×280×110
CRA-18T	18	12	12	30.7	40	510×280×110
CRA-24T	24	16	16	44.5	60	660×370×110
CRA-32T	32	20	20	62.8	87	660×460×110
CRA-40T	40	25	25	68	102	690×460×110

搬运坦克车 Cargo Trolley

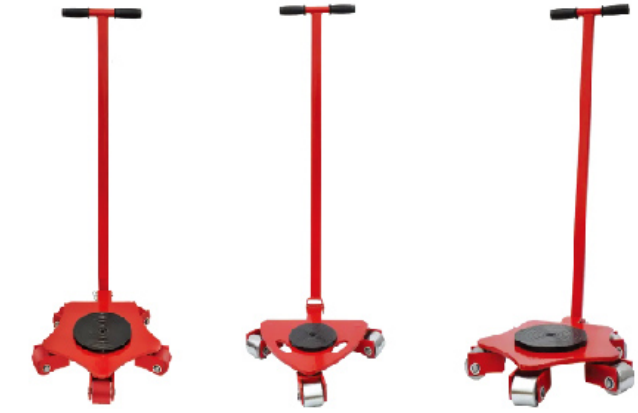

型号 Model	上轴承限重 Upper bearing limit (kg)	额定载荷 Rated load (kg)	轮子数量 Number of wheels	尺寸 Size (cm)	净重 Weight (kg)
CRP-3T	3	2	3	50×48×11.5	27.5
CRP-4T	4	3	4	58×52×11.5	29.5
CRP-5T	5	4	5	63×55×11.5	32.5
CRP-10T	10	8	4	65×56×11.3	60
CRP-15T	15	12	5	72×62×11.3	80

搬运坦克车 Cargo Trolley

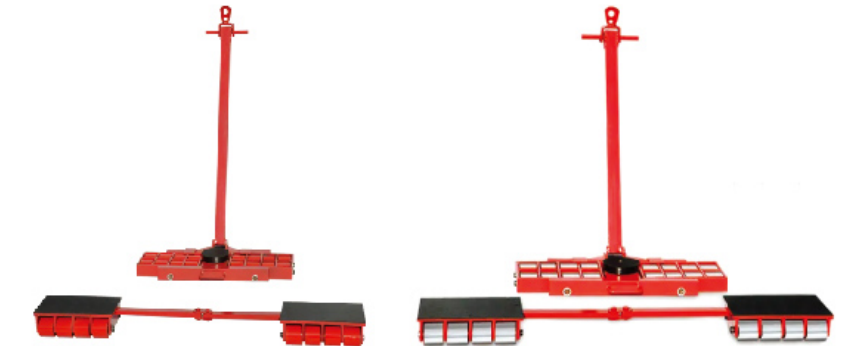

型号 Model	部件 Type	轮子大小 Wheel size (mm)	轮子数量 Number of wheels (pcs)	接触面积 Contact surface size (mm)D	手杠长度 Length of handle (mm)	尺寸 Dimensions (mm) LXWXH	净重 Weight (kg)
X4+Y4	X4	φ80X70	4	D: φ160	F:800	230X230X110	13
X4+Y4	Y4	φ80X70	4	E: 180X140	J:300-1000	180X140X110	15
X8+Y8	X8	φ80X70	8	D: φ160	F:1400	560X420X110	46
X8+Y8	Y8	φ80X70	8	E: 200X160	J:400-1500	200X200X110	28
X12+Y12	X12	φ80X70	12	D: φ200	F:1400	750X450X110	72
X12+Y12	Y12	φ80X70	12	E: 240X180	J:400-1500	260X200X110	36
X16+Y16	X16	φ80X70	16	D: φ200	F:1400	936X500X110	88
X16+Y16	Y16	φ80X70	16	E: 280X200	J:400-1500	310X230X110	46
X18+Y18	X18	φ80X70	18	D: φ200	F:1400	780X550X110	96
X18+Y18	Y18	φ80X70	18	E: 280X200	J:400-1500	320X220X110	52
X24+Y24	X24	φ80X70	24	D: φ200	F:1400	1000X580X120	118
X24+Y24	Y24	φ80X70	24	E: 350X220	J:400-1500	340X320X120	70
X32+Y32	X32	φ80X70	32	D: φ200	F:1400	1080X720X140	175
X32+Y32	Y32	φ80X70	32	E: 440X220	J:400-1500	430X320X140	118

千斤顶 Jacking

名称: 爪式千斤顶
额定载荷: 2.5-25吨
应用: 广泛应用在生产, 机械加工, 运输行业中的设备提升与支撑。

Name: claw jack
Rated load: 2.5T-25T
Application: widely used in manufacturing, machinery, transportation industry for equipment lifting, equipment support

注意: 严禁过载使用, 起升位置位于载荷中心, 千斤顶置于平整有承载能力的平面上。

Note: overload use is strictly prohibited. The claws are lifted and the weight must be raised to the innermost; the jack must be used on a flat load-bearing surface.



型号 Model	MHC-5	MHC-10	MHC-20	MHC-30	MHC-50	MHC-10P
爪部载荷 Claw load U (T)	2.5	5	10	15	25	5
顶部载荷 Top load F (T)	5	10	20	30	50	10
扬程 Head(mm)	117	147	152	155	155	147
高度 Height A (mm)	228	282	310	330	370	282
总伸长量 Total elongation B (mm)	345	429	462	485	528	429
爪部高度 Claw height K (mm)	16	22	25	28	40	22
爪部尺寸 Claw size L1 × W1	69 × 45	98 × 52	123 × 60	149 × 60	190 × 75	98 × 52
主轴直径 Spindle diameter J (mm)	29	42	55	62	85	42
底座尺寸 Base size L × W (mm)	130 × 125	235 × 186	251 × 241	273 × 262	280 × 340	235 × 186
净重 Net weight (kg)	8.5	20.2	31.5	44.0	88.5	20.2

混凝土搅拌机 Concrete Mixer

高品质电机: 100%纯铜电机, 过热保护装置, 防水板
内部结构: 三风叶重力式搅拌性能
筒身和滚轮: 筒身金属沟槽式焊接, 滚轮强力支撑
实体模式: 高压抗磨损
万向轴连接: 转动轴和电机之间简易安装连接, 传动性能好
驱动模式: 电力电机, 汽油驱动电机

Quality Motor: 100% pure copper thermal protection device waterproof plate.
Internal Structure: Three pieces blades gravity type mixing good performance.
Drum and Roller: Drum welded metal rail metal groove type roller strong support force.
Solid Type: Strong compression more wearproof for any situation.
Universal Joint Connection: Between Drum and motor easy to install good transmission
Driven mode: Motor electricity and gas motor.



型号 Model	搅拌重量 Mixing weight (kg)	桶身直径 Barrel diameter (cm)	桶壁厚度 Barrel thickness (mm)	电机功率 Motor power (W)	净重 Net Weight (kg)
120L	34-45	50	2	2500	51
160L	50-75	65	2	2500	56
200L	100-115	65	2	2500	65
240L	125-175	65	2	2500	73
280L	150-225	75	2.5	2500	85
350L	200-275	75	2.5	2800	95
280L 万向轴 universal	150-225	75	2.5	2500	85
350L 万向轴 universal	200-275	75	2.5	2800	95
280L 正反转 Positive and negative	150-225	75	2.5	4000	85
350L 正反转 Positive and negative	200-275	75	2.5	4000	95
400L 正反转 Positive and negative	250-350	75	2.5	4000	105
500L 正反转 Positive and negative	300-400	75	2.5	4000	115